

## Q6 Tile - Award Winning Architectural Appeal



Solar Pros, Architects & Homeowners agree on the superior look & performance of Atlantis' Q-Tile. Now, MORE POWER & a SIMPLER CONNECTION, means Q6-Tile are even better.

Q6-Tile still use the Eternit roofing tile – one of Europe's predominant roofing manufacturers. Q6-Tile's are one of the only solar roofing solutions that satisfy historic commissions, zoning commissions and code restrictions.

### I. Electrical Specifications

Power [ STC ]	23.83	Watt ± 5 %
Vmpp	3.198	Volt DC
Voc	3.70	Volt DC
Imp	7.90	Amp DC
Isc	8.38	Amp DC

Power [ PTC ]	19.07	Watt
NOCTiii	49.6	°C
Temp. Coefficient	- 12.75	mV DC / °K

Maximum system voltage: 1000 VDC



### II. Physical Dimensions

1. Solar Electric Laminate: Six (6) high efficient solar cells connected in series
2. Specialized **PLUG-N-PLAY** junction box that is used to make the connections on the roof. **NO TOOL REQUIRED**
3. Highly durable Eternit Roofing tile. The laminate (1) is permanently attached to the roofing tile.

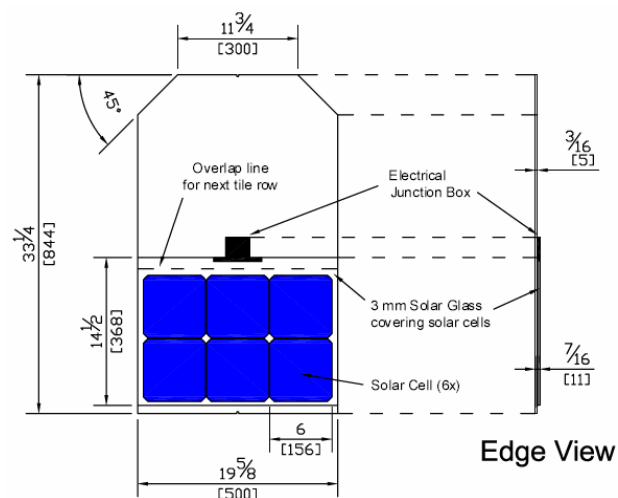

Q6-Tile weight each 14.4 lb.  
 Q6-Tile per 100 sqft 50.6 ea.  
 Q6-Tile weight per 100 sqft 730 lb.



Atlantis Standard Warranty - 20 years limited warranty on power output<sup>i</sup>

### **Hurricane-Strength Wind Rating**

Atlantis has tested the Q6-Tile and has secured a high wind rating in excess of 100 mph (160 km/hr.) and is capable of withstanding hurricane-strength winds!

Atlantis developed a new, *easy-snap* J-Box for slate-to-slate Q6-Tile connections. More power & a quick connect J-Box makes Q6-Tile install a smooth experience.



---

<sup>i</sup> See dealer for details

**EAST**  
306 Amherst Road,  
Pelham, MA 01002  
917-886-4793  
302-288-6680 (F)

**MAIN WEST**  
4517 Harlin Drive  
Sacramento, CA 95826  
916-438-2930  
916-438-2935 (F)

**SoCAL - WEST**  
17150 Newhope St, Suite 1001  
Fountain Valley, CA 92708  
714-546-4411  
714-546-4412 (F)