

## ET MODULE

### ET-M54050 50Wp

#### EFFICIENCY

- Low voltage-temperature coefficient ensures high-temperature operation
- Exceptional low-light performance combined with high sensitivity to light enables excellent energy delivery

#### MATERIALS

- Highest quality, high-transmission tempered glass provides enhanced stiffness and impact resistance
- Advanced EVA encapsulation system with triple-layer back sheet meets the most stringent safety requirements for high-voltage operation
- A sturdy, anodized aluminum frame allows modules to be easily roof-mounted with a variety of standard mounting systems
- Ultra reliable bypass diodes prevent damage through overheating due to shaded or defective cells

#### BENEFITS

- Manufactured in an ISO 9001:2000 certified plant
- High efficiency, high safety, high reliability
- Output power tolerance of +/-3%
- 25-year limited warranty on power output, 5-year limited warranty on materials and workmanship



## ET SOLAR GROUP [www.etsolar.com](http://www.etsolar.com)

#### ET Solar China

24F, A2 World Trade Center Mansion,  
67 Shanxi RD, Nanjing 210009, China  
Tel: +86 25 8689 8096 Fax: +86 25 8689 8097  
Email: [sales@etsolar.com](mailto:sales@etsolar.com)

#### ET Solar USA

4900 Hopyard Road, Suite 290,  
Pleasanton, CA 94588, USA  
Tel: +1 925 4609 898 Fax: +1 925 4609 929  
Email: [sales@etsolar.us](mailto:sales@etsolar.us)

#### ET Solar Europe

ET Solar GmbH, Munich City Tower,  
Landsbergerstr. 110 / 9 Fl. D-80339 Munich, Germany  
Tel: +49 89 309040 263 Fax: +49 89 309040 466  
Email: [sales@etsolar.de](mailto:sales@etsolar.de)  
(Italy Office) Tel: +39 392 2340606 Email: [sales@etsolar.it](mailto:sales@etsolar.it)

# ET Module

ET-M54050

## SPECIFICATIONS

Model type	ET-M54050
Peak power(Pmax)	50W
Weight	5.0kg(11.0lbs)
Dimensions	719×555×34mm(28.3×21.9×1.3inch)
Maximum power voltage (Vmp)	20.2V
Maximum power current (Imp)	2.48A
Open circuit voltage (Voc)	24.6V
Short circuit current (Isc)	2.81A
Maximum system voltage	DC 1000V
Temp. Coeff. of Isc (TK Isc)	0.06 %/ °C
Temp. Coeff. of Voc (TK Voc)	-0.397 %/°C
Temp. Coeff. of Pmax (TK Pmax)	-0.549 %/°C
Normal Operating Cell Temperature	44.4±2 °C

Note: the specifications are obtained under the Standard Test Conditions (STCs): 1000 W/m<sup>2</sup> solar irradiance, 1.5 Air Mass, and cell temperature of 25 °C.

## PHYSICAL CHARACTERISTICS Unit:mm(inch)

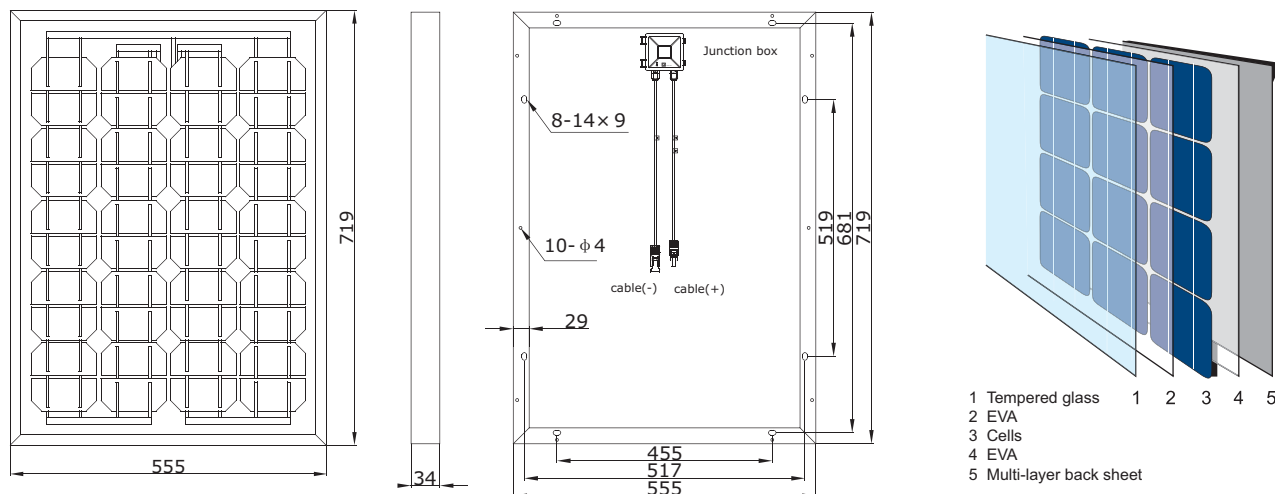

Electrical Performance cell temperature:25°C

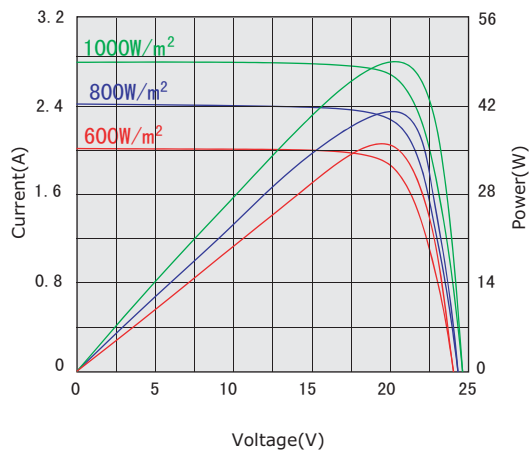

Temperatur dependence of Isc,Voc and Pmax

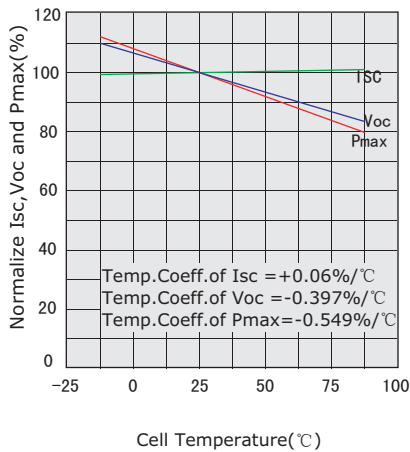

Please contact Support@etsolar.com for technical support